



Team with AES on Your Next Gas Equipment Project

Trust Our Equipment Experts to Deliver for You and Your Customers

Gas source and distribution systems are a critical component of industrial, R&D, and high-tech environments, powering applications that are core to consistent, innovative operations. Any contractor, architect, or engineer that deals in these environments needs a go-to Equipment Expert that can deliver reliable, robust system solutions as part of their successful build-out.

When you need specialty expertise on a gas delivery system that will meet your customer’s process requirements and work within the environment you are creating, turn to AES for the answers.

AES is a proven partner to provide your customers with the highest quality gas delivery equipment that meets their specific operational demands. Our diverse portfolio of offerings can scale to satisfy the range of your clients’ unique high and ultra high purity gas delivery needs while maintaining premier levels of precision, purity, and performance. **Here’s how we do it:**

A Different Kind of Value-Added Partnership

AES supplements the construction capabilities you bring to the table with our highly focused gas delivery systems expertise. While other equipment providers split their focus—typically concentrating primarily on molecules with systems as a secondary means to supply those gases—we work exclusively to ensure our systems uphold the integrity of the gases they handle.

By partnering with AES you gain:

- Stronger customer relationships
- Equipment expertise
- Optimized processes within the environment
- Solutions that add value

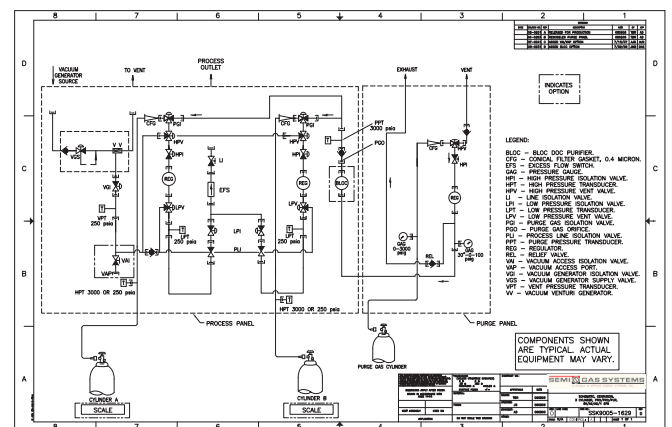

Add AES to Your Network of Preferred Partners

To learn how we can work together to solve your gas delivery equipment challenges, contact AES at info@appliedenergysystems.com.



Diverse Solutions with the Same High Standards of Quality

From research labs to advanced fabs to large-scale manufacturing plants, our team has supplied gas delivery systems to hundreds of customers across high-tech, industrial, government, and life sciences sectors.

Our SEMI-GAS® and VERSA-GAS™ equipment lines have been successfully operating in these diverse environments for decades, and are globally respected for their reliability, safety, and performance—capable of consistently upholding the highest levels of precision and purity while ensuring adaptability to meet your customers' specific system requirements.



SEMI-GAS®

ULTRA HIGH PURITY GAS DELIVERY SYSTEMS

Serving Tier 1 semiconductor leaders and high-tech innovators with **premier, production-ready UHP gas delivery solutions that conform to SEMI S2 standards**



VERSA-GAS™

HIGH PURITY GAS DELIVERY SYSTEMS

Serving a diverse range of verticals that seek **safe, reliable, cost-effective high purity gas delivery solutions that scale to the size and scope** of their application

Custom Equipment for Distinct Applications

We know that gas delivery demands can vary greatly, and leverage our experience across industries to provide you with equipment that is optimized to your client's distinct application.

Through a methodical 'Applied Solution' process, we combine our proven product offerings with our specialized equipment engineering capabilities to create a custom system as unique as your customer's process requirements. Our Applied Solutions are used across industries including:

- > **Semiconductor and Electronics**
- > **Pharmaceuticals and Biotechnology**
- > **Industrial Manufacturing**
- > **Research Laboratories and Universities**
- > **Photovoltaics and Solar**
- > **Aerospace and Defense**

Why AES?

Applied Energy Systems (AES) is the premier provider of high and ultra high purity gas systems, services, and solutions. Since 1968, customers have turned to AES for high-value systems engineering—including design, manufacturing, testing, and field services. Whether equipment requirements are driven by regulation, innovation, or both, AES brings together its specialized engineering capabilities and vast scope of product offerings to create the gas delivery solutions that meet business-critical process demands.

With two industry-leading equipment divisions, SEMI-GAS® and VERSA-GAS™, as well as full equipment customization capabilities, AES addresses high purity and ultra high purity gas delivery needs for a diverse range of industries, including semiconductors and electronics, pharmaceuticals and biotechnology, photovoltaics, manufacturing, research laboratories, universities, and more.

Your customer's standards are high. Your standards are too.
Don't settle for anything less from your gas delivery equipment partner.

To learn how we can work together to deliver the high-quality, comprehensive gas delivery solutions your customers need, contact AES at info@appliedenergysystems.com.



180 Quaker Lane, Malvern, PA 19355

PHONE: 610.647.8744 FAX: 610.640.4548

www.appliedenergysystems.com

PARTNER WITH AES:

Learn more at appliedenergysystems.com/partner today.

CONTRACTOR-091217-V1